

## Hygienic storage solutions for coldrooms & cleanrooms







## Optima Shelving™

Application & advantages .....	pg 4
Composition & dimensions .....	pg 6
Basic configuration .....	pg 10

## Mobile Optima Shelving™

Composition .....	pg 12
Dimensions .....	pg 14
Examples .....	pg 15

## Optima Shelving™ Trolleys

Composition .....	pg 16
Dimensions .....	pg 18
Trolley configurations .....	pg 19

## Parts

Individual Shelf Level .....	pg 22
Grill / Plate Version .....	pg 22
Corner Connector .....	pg 22
Upright Standard & Extension .....	pg 22
Mobile Upright .....	pg 22
Rim-bar .....	pg 23
Alu Rail .....	pg 23
Hook .....	pg 23
Trolley Upright .....	pg 23

© 2016 Castel Engineering Sprl - Belgium. All pictures and drawings in this literature are for illustration purposes only. Data may change without prior notice and are subject to tolerances. Castel Engineering Sprl, its Affiliates and its Distributors cannot be held liable for typographical errors, layout errors or technical misinformation contained herein.

## Online configurator

Customers can use our web-based application to design their own configuration with standard shelf elements to fit in the room. The program only requires the input of basic room and shelf parameters. It features a user-friendly drawing area where the customer will be helped with the design and the positioning of the shelves.

From there on, the application does the rest: list and quote all necessary elements as well as issue the assembly sequence for the installer on the site.





## Optimize your storage!

The Optima Shelving™ offers an ideal storage solution for the food and pharmaceuticals industries. Strong aluminium structure and durable plastic shelves provide an excellent load capacity. A wide range of dimensions and universal connectors offer the possibility to virtually extend the shelves without any limitation. Countless combinations of shelf configurations, from a single rack to L, U or T-shaped extensions, allow you to optimize your storage space.



## Fast & easy assembly

Fast and easy assembly by one single person. No tools required.





## High quality materials

- Decorative anodised aluminium finish
- Durable polypropylene shelf plates and grills
- Hooks made from reinforced metal
- Feet & inserts made from high-resistance composite materials
- Stainless steel corner connectors



## Functional advantages

- Extremely stable, excellent load capacity
- Adjustable shelf level every 150 mm
- Hidden fixing connections
- Adjustable feet
- Easy removable shelf grills and plates
- Dishwasher-proof shelf inserts
- Excellent resistance between -40°C and +80°C



## Applications

Coldrooms, cleanrooms, catering, laboratories, chemists, laundries and stores.



# Optima Shelving™

## Composition

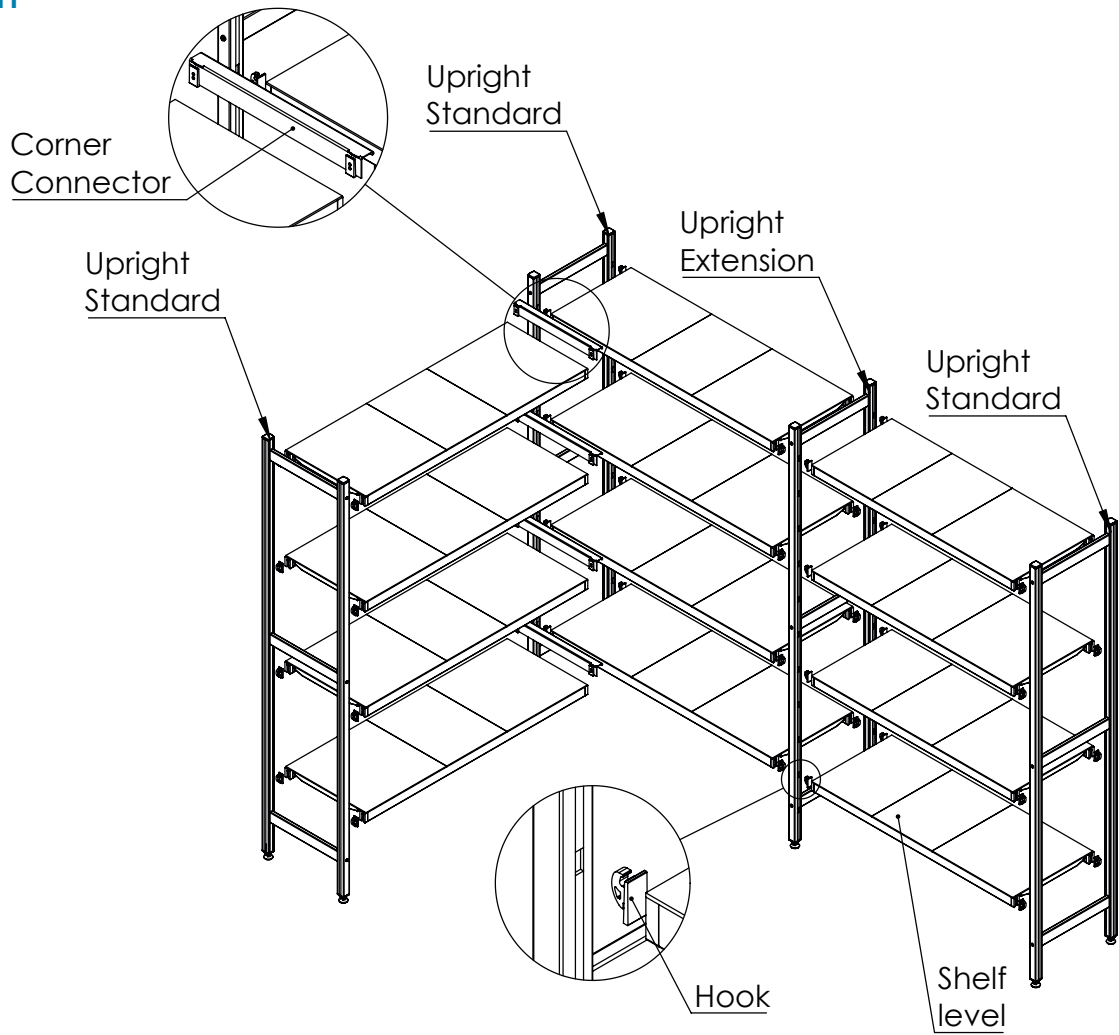



## General drawing

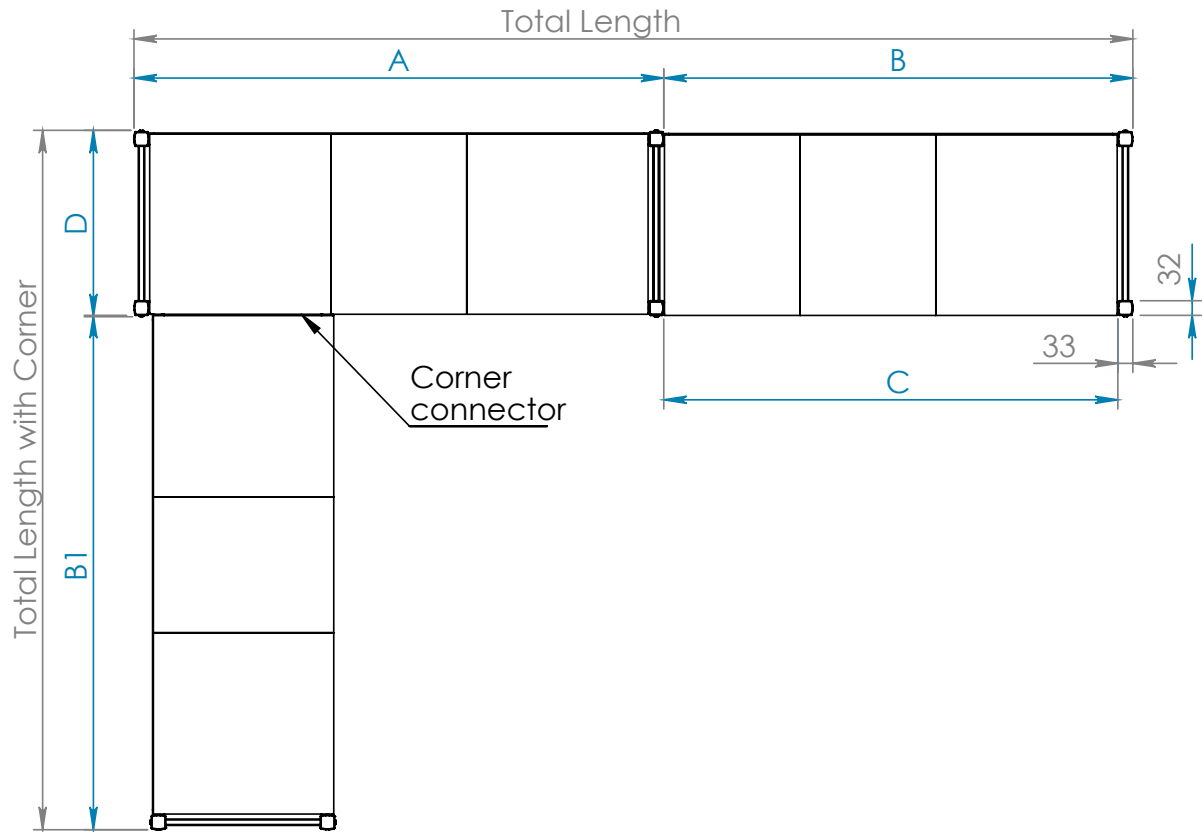

		Measurements (mm)												
A		663	763	863	960	1060	1160	1260	1357	1457	1557	1657	1754	1854
B/B1		630	730	830	927	1027	1127	1227	1324	1424	1524	1624	1721	1821
C		597	697	797	894	994	1094	1194	1291	1391	1491	1591	1688	1788
D*		308	408	508	608	* Depth dimensions include additional 8 mm for the screws								



## Overall shelves lengths - size A

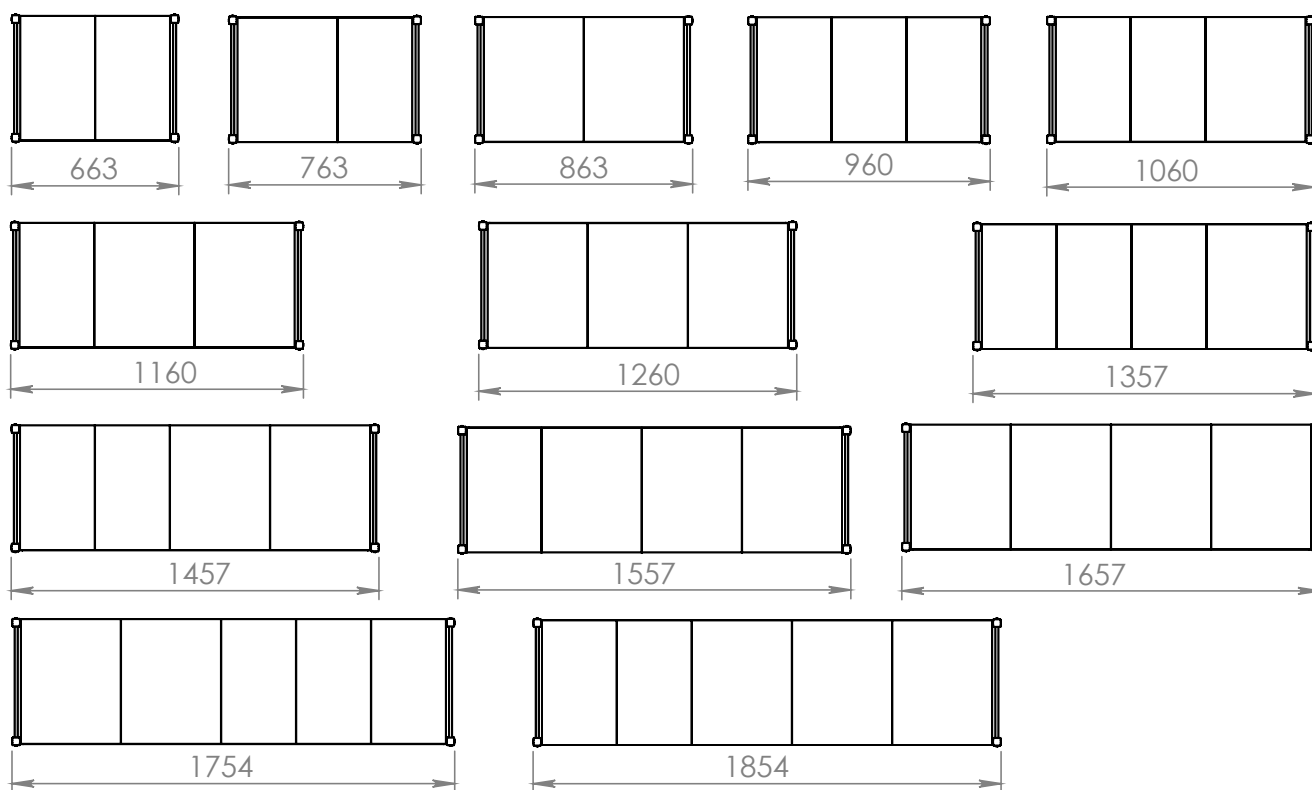

Loading capacity per shelf level													
Shelf length (mm)	663	763	863	960	1060	1160	1260	1357	1457	1557	1657	1754	1854
Max load per level (kg)	280	260	240	210	200	180	160	150	140	130	120	110	100

The values are mentioned for evenly distributed load. Max weight between 2 uprights 900 kg, for corner configuration 600 kg between 2 uprights

## Overall depths- size D

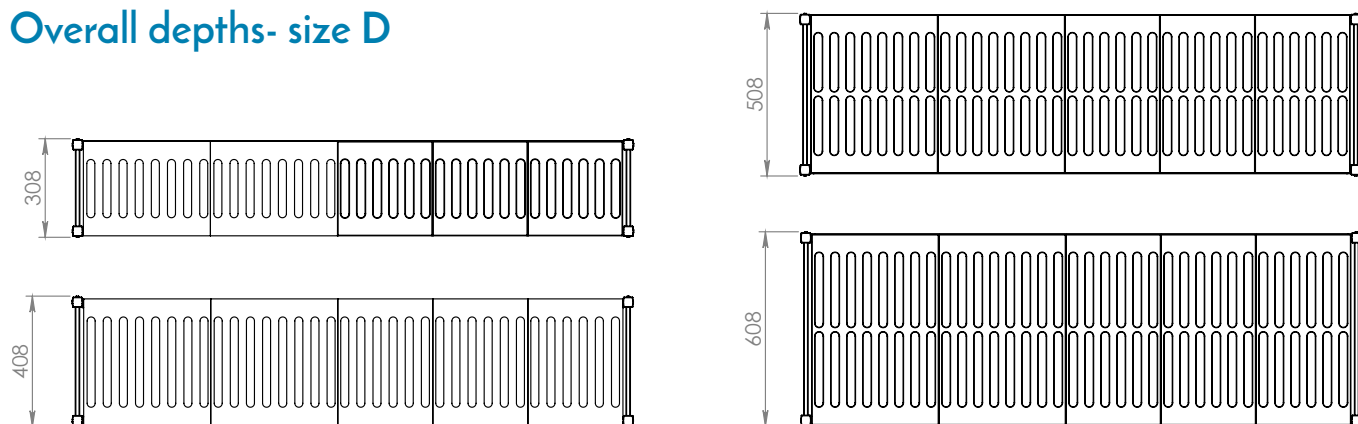

Standard overall depths (mm)			
308	408	508	608



## Possible positioning of shelf levels

Height: 1800 mm  
e.g. 3 / 4 / 5 levels  
max. 11 levels

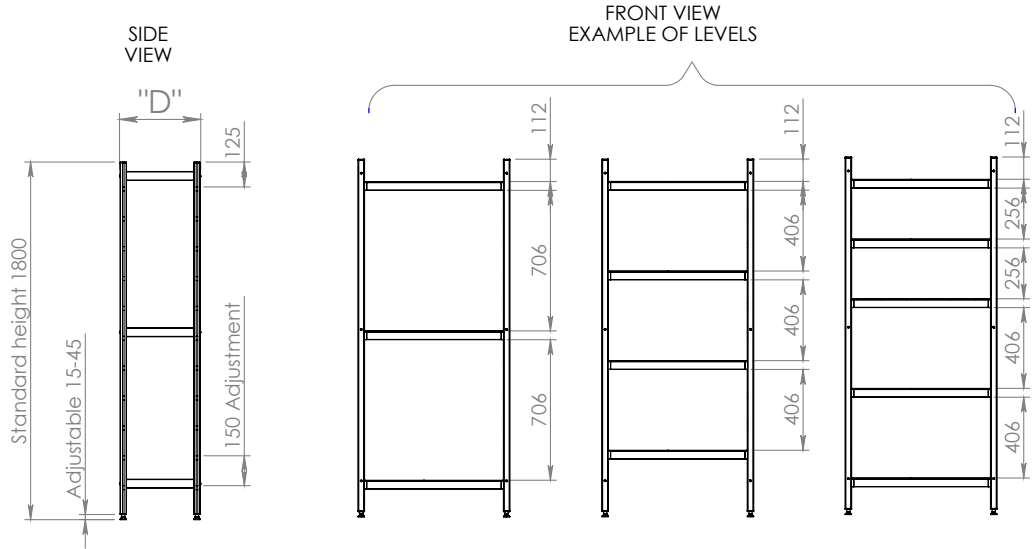

Height: 2100 mm  
e.g. 3 / 4 / 5 levels  
max. 13 levels

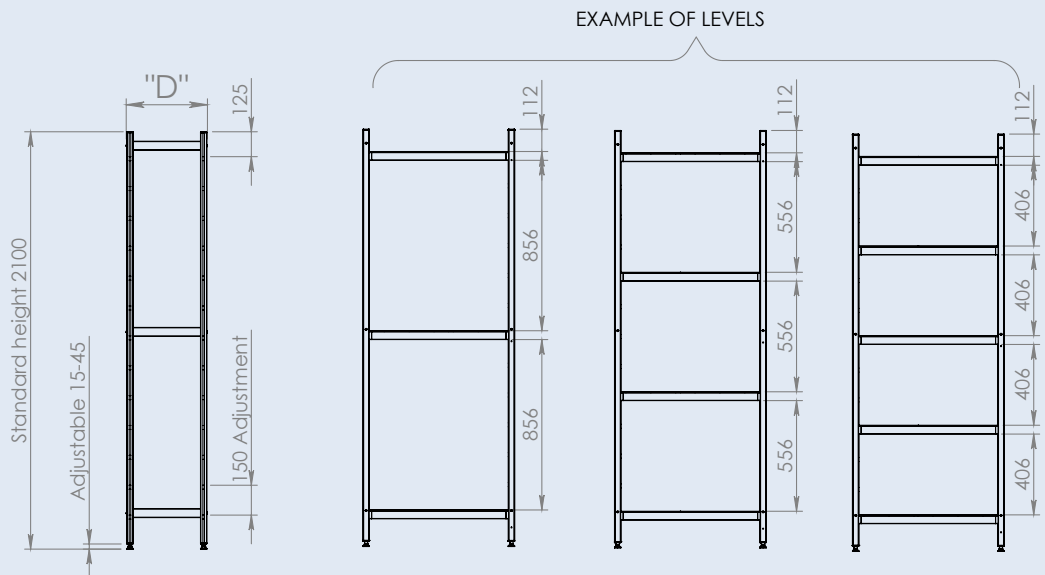

Height: 2400 mm  
e.g. 3 / 4 / 5 levels  
max. 15 levels

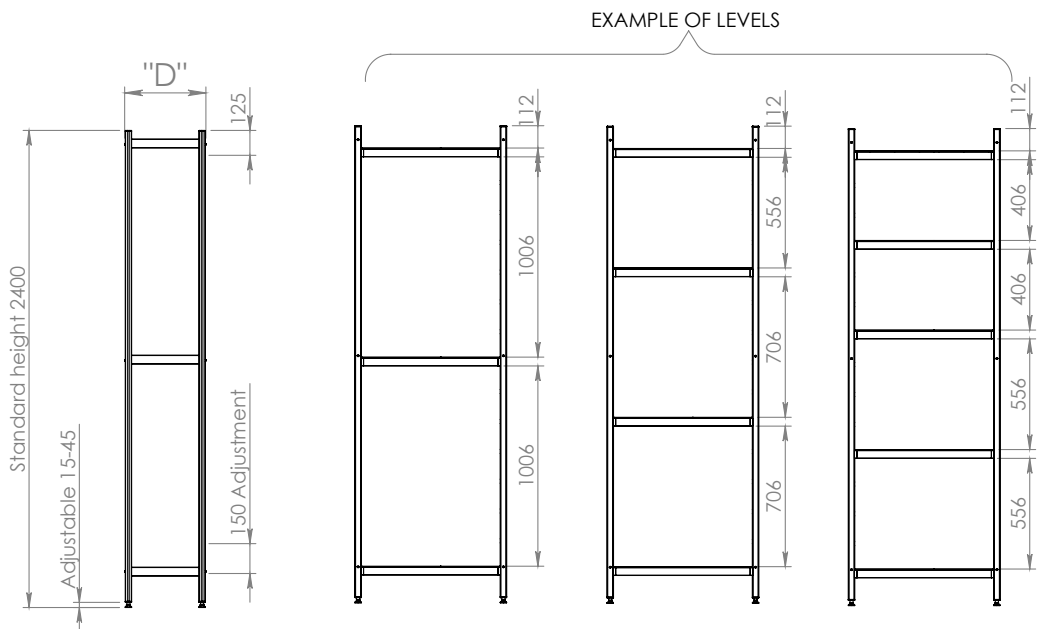

## Configurations

Basic shelving

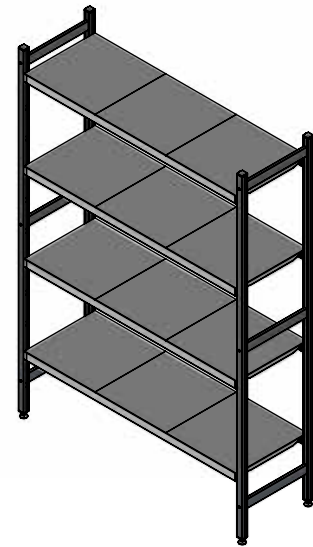

Basic shelving + line extension

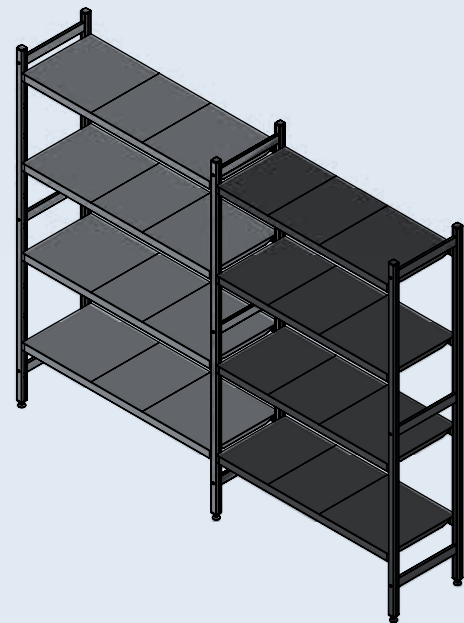
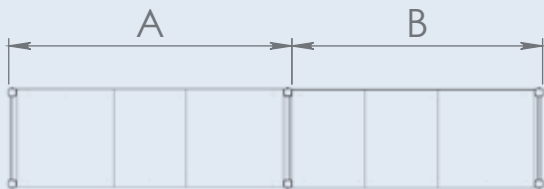

L-shape 1  
Basic shelving + corner extension

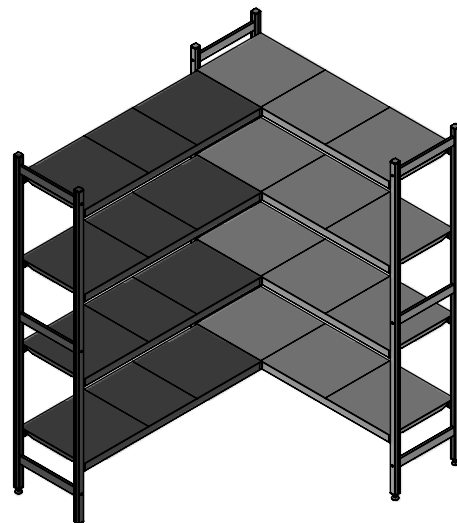
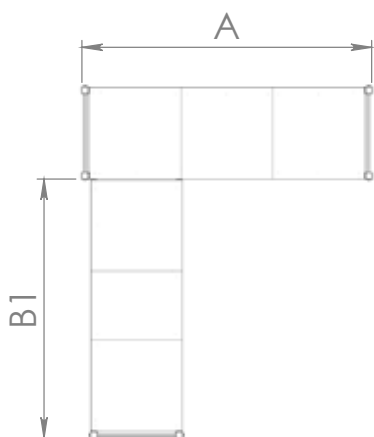

Dimensions A/B/B1/C: see page 7



L-shape 2  
Basic shelving + line extension + corner extension

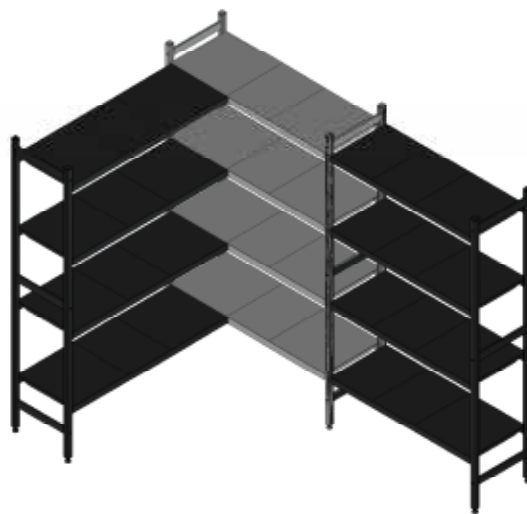
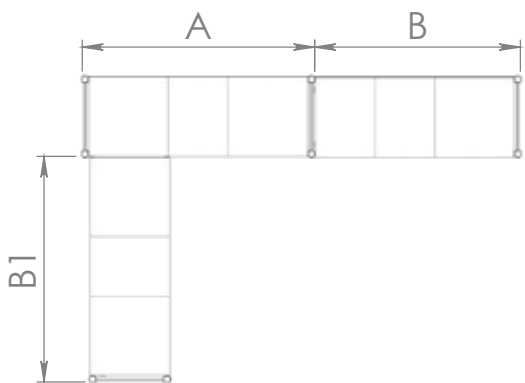

U-shape 1  
2 x basic shelving + shelving levels fixed on both sides

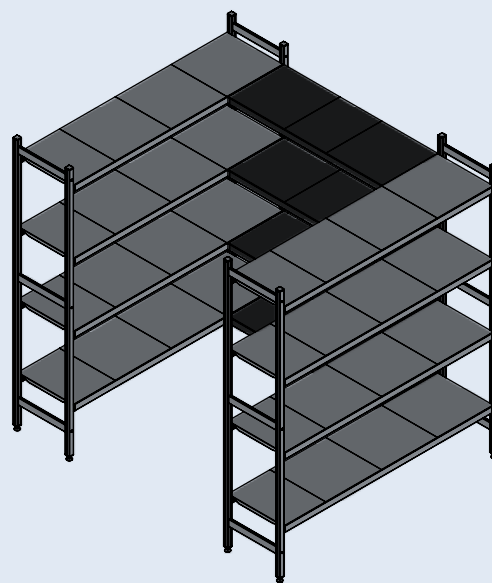
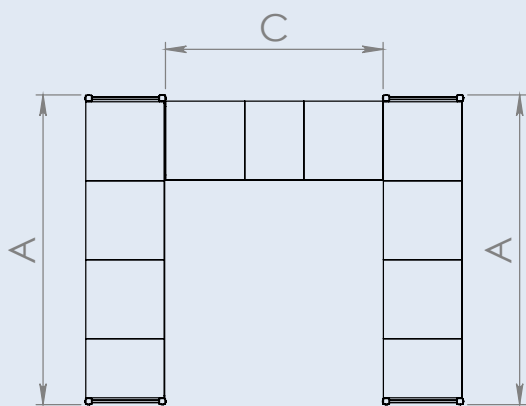

U-shape 2  
Basic shelving + 2 x corner extension

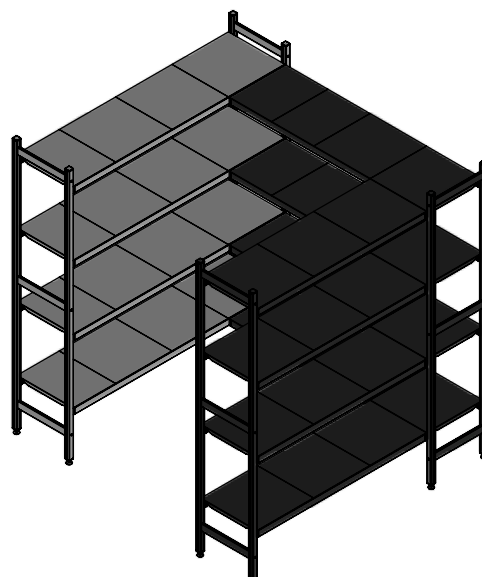
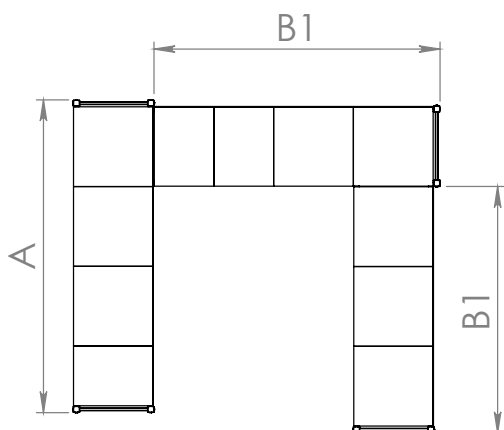

## Mobile Optima Shelving™

### Maximum storage space in small areas

- Based on standard Optima Shelving™
- Equipped with durable casters, precisely moving along channels
- Combining mobile & modular shelving will allow to configure a more ergonomic storage system

### Composition

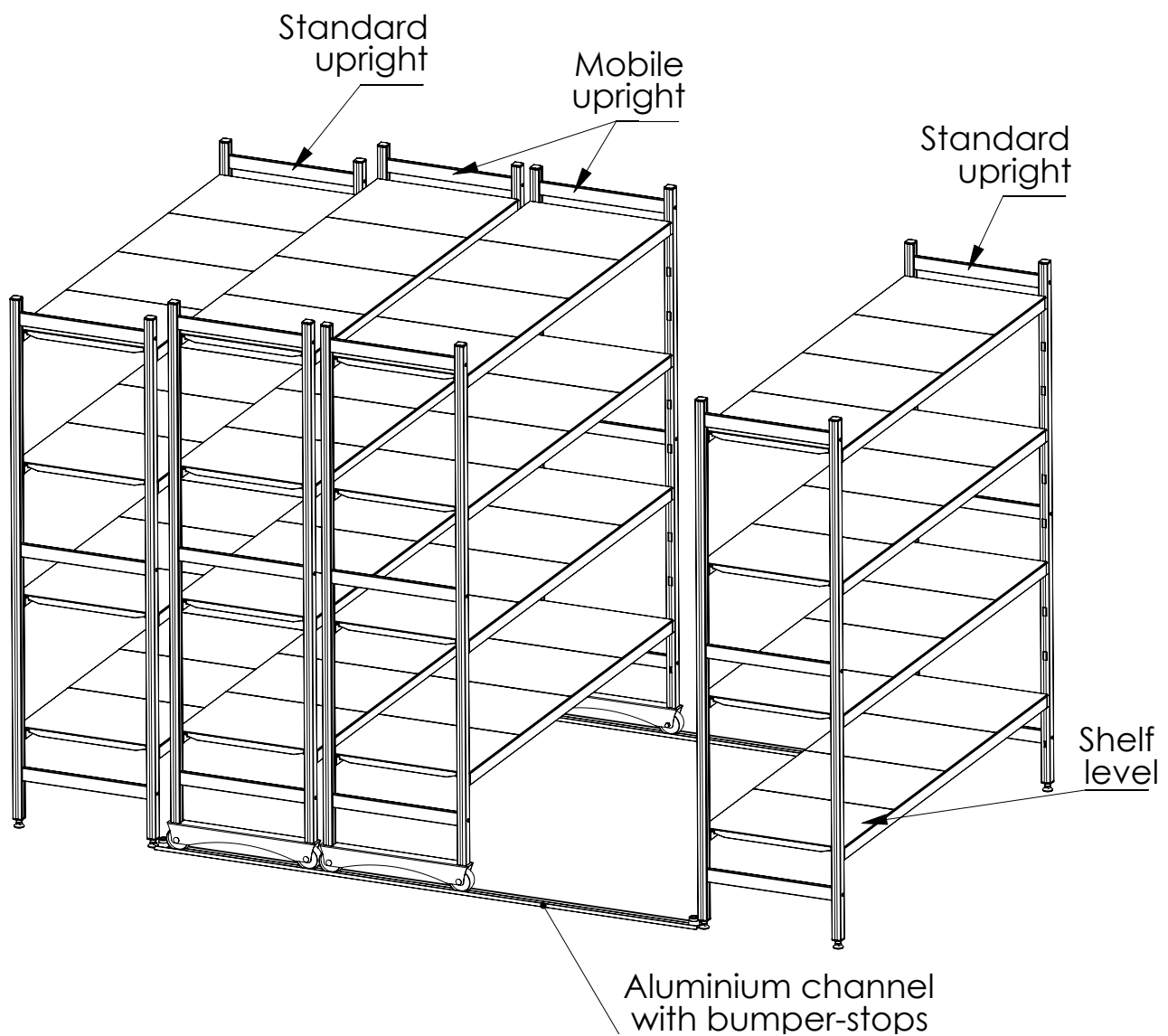





## Dimensions

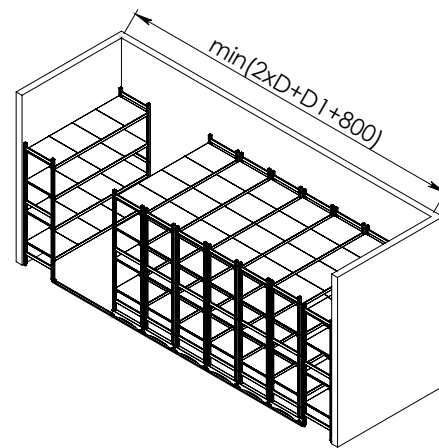
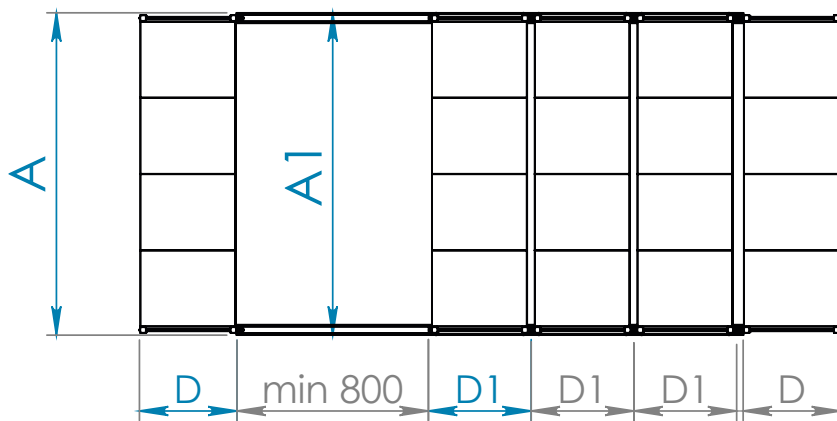
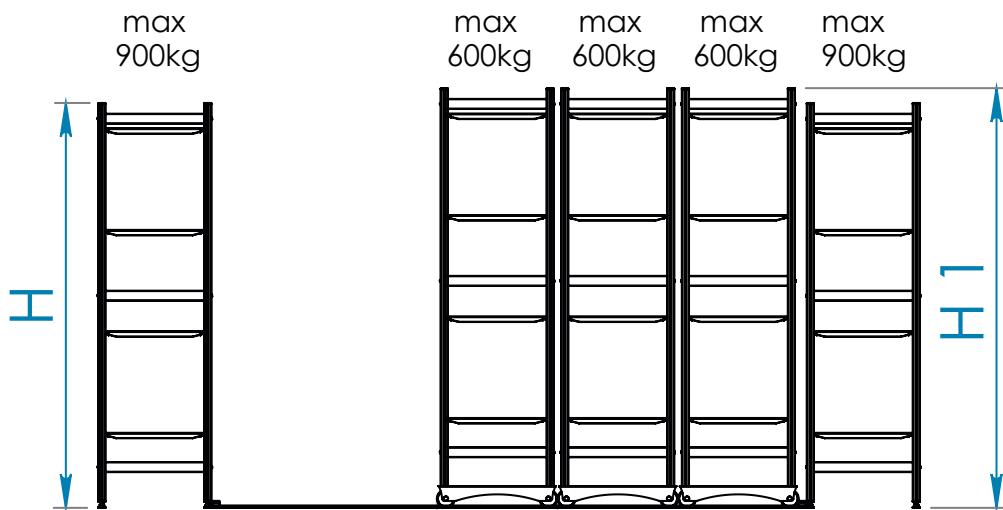

Standard length (mm)													
A	663	763	863	960	1060	1160	1260	1357	1457	1557	1657	1754	1854
A1*	698	798	898	995	1095	1195	1295	1392	1492	1592	1692	1789	1889

Standard depth (mm)			
D		408	508
D1*		435	535

Standard height (mm)			
H		1800	2100
H1*		1864	2164

\* Overall dimensions



## Examples

Optima shelving™ offers endless possibilities to design your storage space.  
Our engineers are available to answer all your questions.

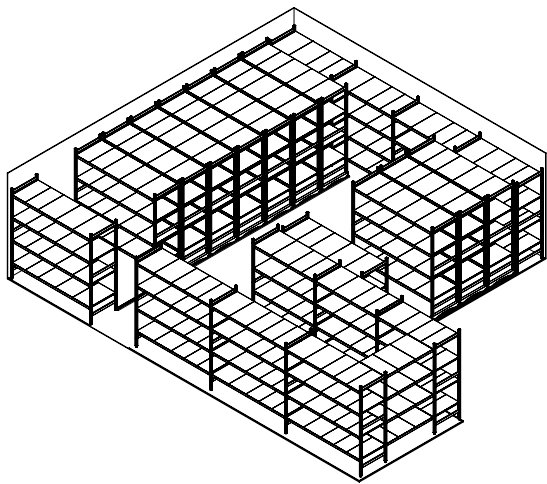

Example 1  
Combination of standard Optima Shelving™  
+ Optima mobile Shelving™

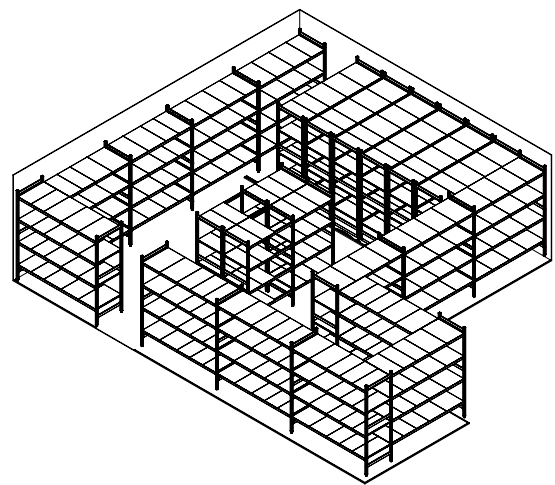

Example 2  
Combination of standard Optima Shelving™  
+ Optima mobile Shelving™



# Optima Shelving™ trolley

Bring your storage wherever you want

- The Optima Shelving™ trolleys combine a shelf with the feature of a tray on wheels.
- Extremely convenient for frequent and easy moving.
- Other dimensions available on request.

## Composition

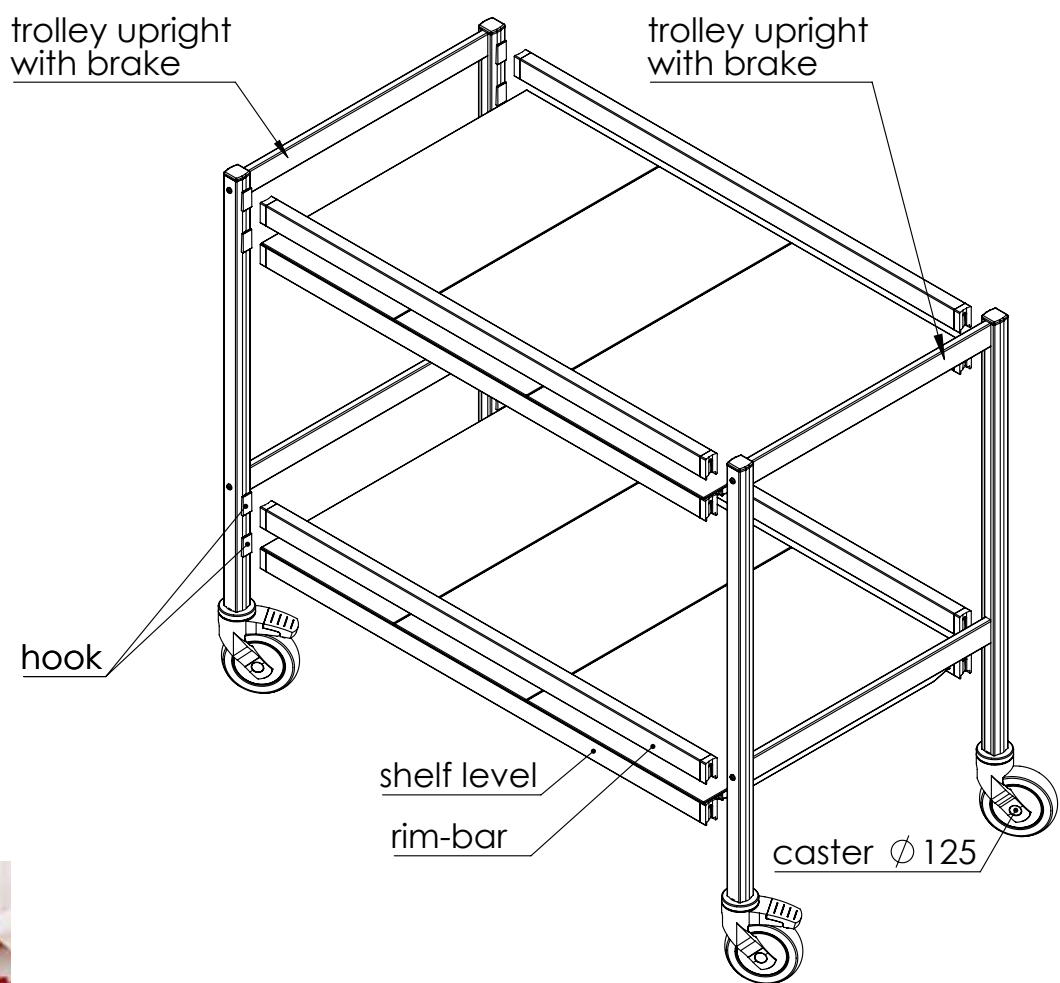

## Casters

- Set of 4, including 2 units with brakes
- Standard diameter 125 mm, optional 75 mm on request

		Standard height (mm)												
		400			1000				1550			1925		
		Loading capacity per shelf level												
Shelf length (mm)		663	763	863	960	1060	1160	1260	1357	1457	1557	1657	1754	1854
Max load per level (kg)		280	260	240	210	200	180	160	150	140	130	120	110	100

The values are mentioned for evenly distributed load. Max weight between 2 uprights 400 kg.







## Dimensions

	Total length (mm)												
A*	663	763	863	960	1060	1160	1260	1357	1457	1557	1657	1754	1854
AI	688	788	888	985	1085	1185	1285	1382	1482	1582	1682	1782	1882

	Total depth (mm)			
D	308	408	508	608
DI*	348	448	548	648

	Possible dimensions between shelves (mm) - only for trolley without rim-bar			
EI	107	257	407	557

\* Overall dimensions



## Trolley configurations

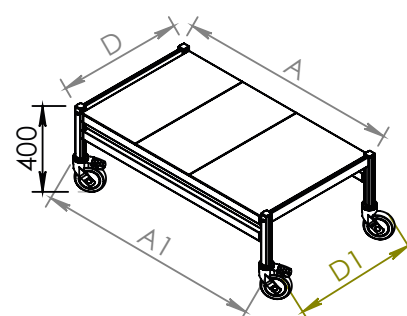
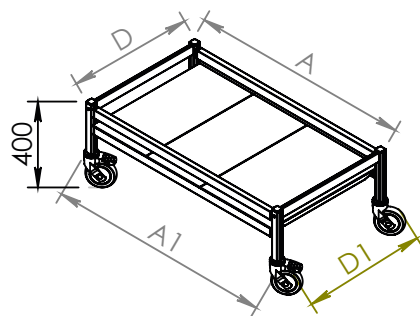

Trolley 400 mm high

	Without rim-bar		With rim-bar	
	Plate	Grill	Plate	Grill
Height	400 mm	400 mm	400 mm	400 mm
N° shelf	1	1	1	1
Shelf fixed/adjustable	Adjustable	Adjustable	Fixed	Fixed
Code	OTPL	OTGR	OT1BPL	OT1BGR

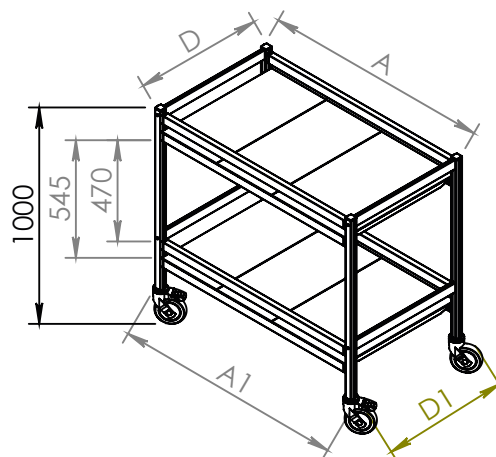
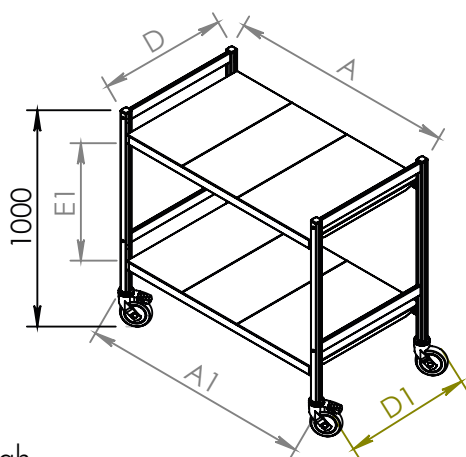

Trolley 1000 mm high

	Without rim-bar		With rim-bar	
	Plate	Grill	Plate	Grill
Height	1000 mm	1000 mm	1000 mm	1000 mm
N° shelf	2-4	2-4	2	2
Shelf fixed/adjustable	Adjustable	Adjustable	Fixed	Fixed
Code	OTPL	OTGR	OT2BPL	OT2BGR

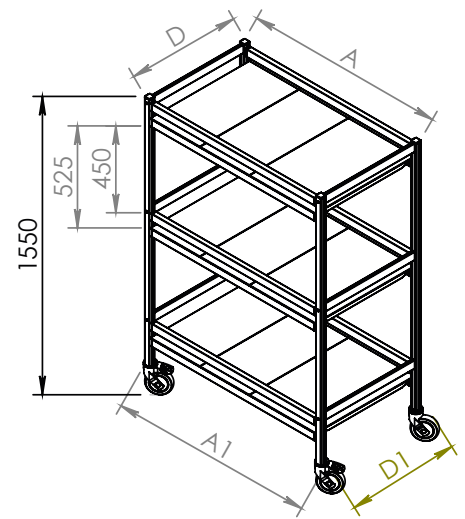
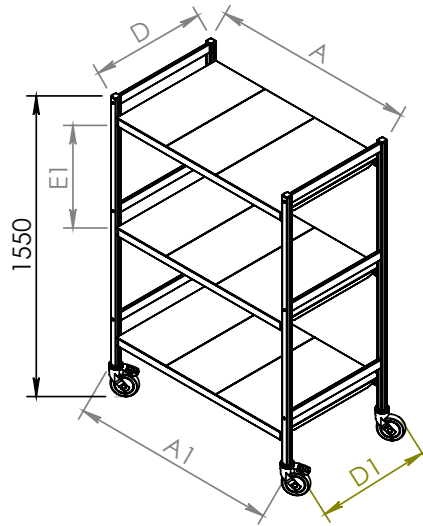

Trolley 1550 mm high

	Without rim-bar		With rim-bar	
	Plate	Grill	Plate	Grill
Height	1550 mm	1550 mm	1550 mm	1550 mm
N° shelf	2-7	2-7	3	3
Shelf fixed/adjustable	Adjustable	Adjustable	Fixed	Fixed
Code	OTPL	OTGR	OT3BPL	OT3BGR

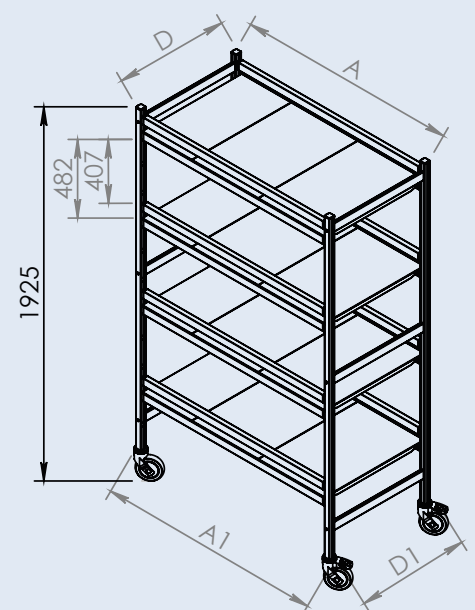
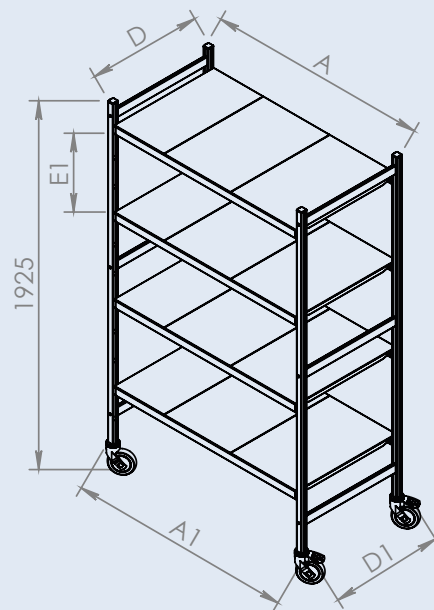

Trolley 1925 mm high

	Without rim-bar		With rim-bar	
	Plate	Grill	Plate	Grill
Height	1925 mm	1925 mm	1925 mm	1925 mm
N° shelf	3-11	3-11	4	4
Shelf fixed/adjustable	Adjustable	Adjustable	Fixed	Fixed
Code	OTPL	OTGR	OT4BPL	OT4BGR



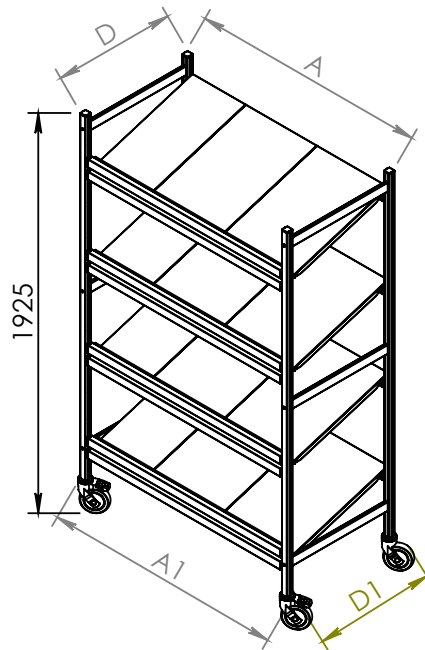

Trolley sloped shelf

	With rim-bar	
	Plate	Grill
Height	1925 mm	1925 mm
N° shelf	4	4
Shelf fixed/adjustable	Fixed	Fixed
Code	OTBSLPL	OTBSLGR



## Parts

### Individual Shelf Level

Hooks included / Individual packaging

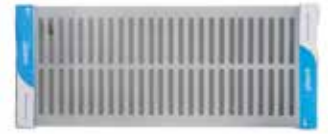
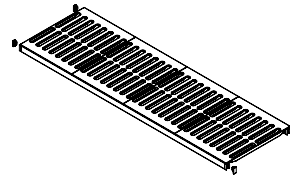

Standard depth (mm)															
300 mm				400 mm				500 mm				600 mm			
Level Length (mm)															
597	697	797	894	994	1094	1194	1291	1391	1491	1591	1688	1788			

### Grill/Plate Version

Dishwasher-proof

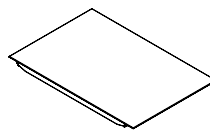
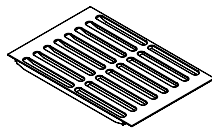

Standard depth (mm)															
300 mm				400 mm				500 mm				600 mm			
Level Length (mm)															
597	697	797	894	994	1094	1194	1291	1391	1491	1591	1688	1788			

### Corner Connector

For 1 level /Stainless steel

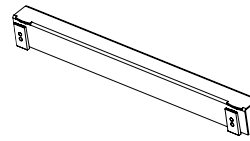

Standard depth (mm)			
300	400	500	600

### Standard Upright & Extension

Equipped with adjustable feet

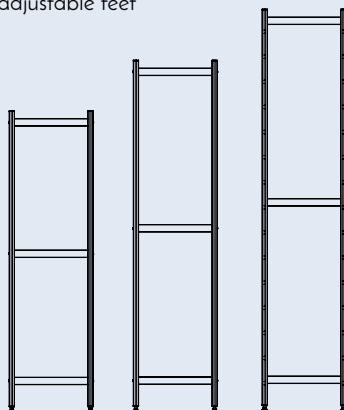

Standard depth (mm)			
308	408	508	608
Standard height (mm)			
1800	2100	2400	

### Mobile Upright

Equipped with preassembled caster set

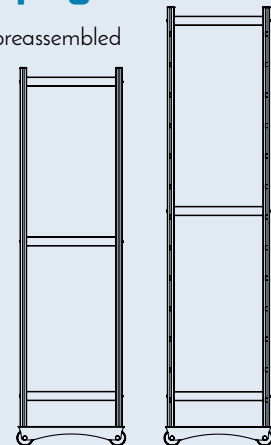

Standard depth D/D1 (mm)		
408/435	508/535	608/635
Standard height (mm)		
1860	2160	

## Rim-bar

Anodized aluminium / Hooks included

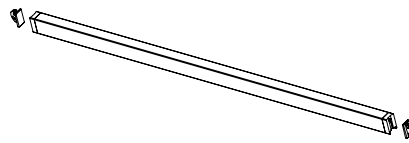

Length (mm)												
597	697	797	894	994	1094	1194	1291	1391	1491	1591	1688	1788

## Alu Rail

Reinforced anodized aluminium  
Bumpers with fittings included

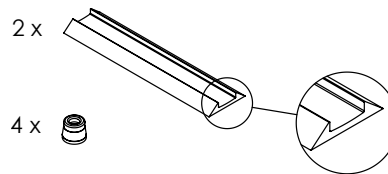

Length (mm)			
2100	3000	4000	6100

## Hook

Made from reinforced metal

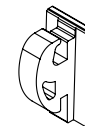

## Trolley Upright

Delivered with preassembled casters

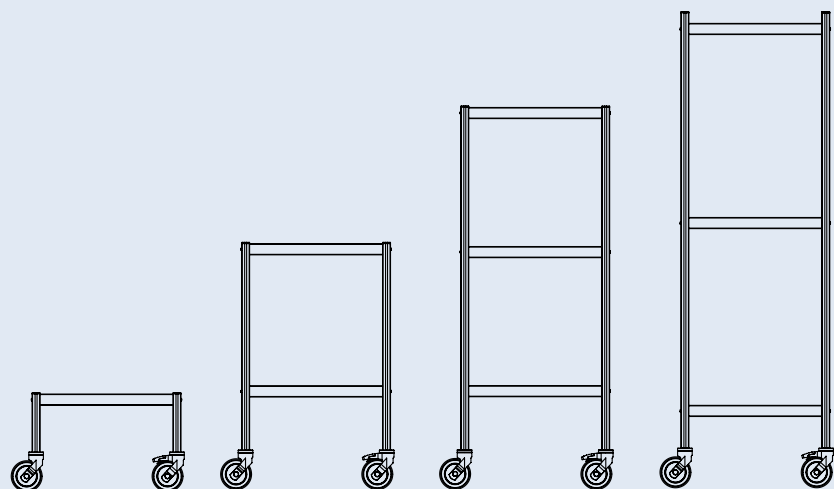

Standard depth D/D1 (mm)			
308/348	408/448	508/548	608/648
Standard height (mm)			
400	1000	1550	1925





**Engineering solutions, manufacturing quality**

**Castel Engineering Belgium - Head Quarters**

Rue de la Royenne 84 -7700 Mouscron - Belgium

T +32 (0)56 33 68 40 - F +32 (0)56 33 78 10

[info@castel-engineering.com](mailto:info@castel-engineering.com)

**Castel Engineering UK**

Units 4&5, The Townsend Centre  
Blackburn Road - Haughton Regis - Beds  
LU5 5BQ - UK

T +44 (0) 1582 66 33 88

F +44 (0) 1582 47 20 50

[sales@castelengineering.co.uk](mailto:sales@castelengineering.co.uk)

**Castel Engineering Polska Sp. z o.o.**

Tomaszowice Kol. 123

21-002 Tomaszowice - Polska

T +48 (0)81 503 28 22

F +48 (0)81 503 15 55

[biuro@castel-engineering.com](mailto:biuro@castel-engineering.com)

**Castel Engineering  
SDN. BHD. Malaysia**

[info@castel-engineering.com](mailto:info@castel-engineering.com)

**[www.castel-engineering.com](http://www.castel-engineering.com)**